

REVISION HISTORY				
ECO Number	REV	DESCRIPTION	CHECKED BY	DATE
	1	Initial design concept	M Dawes	04/03/2011

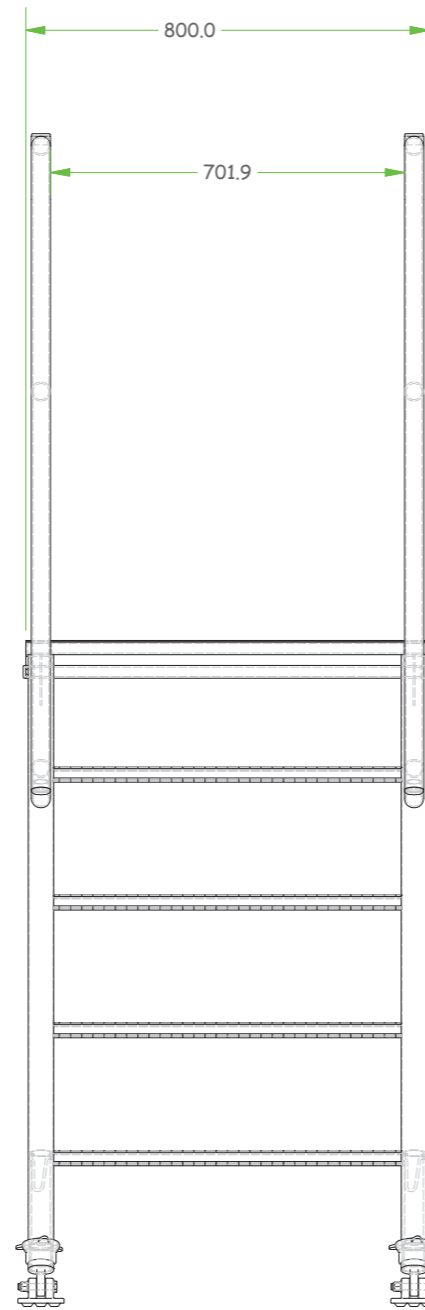
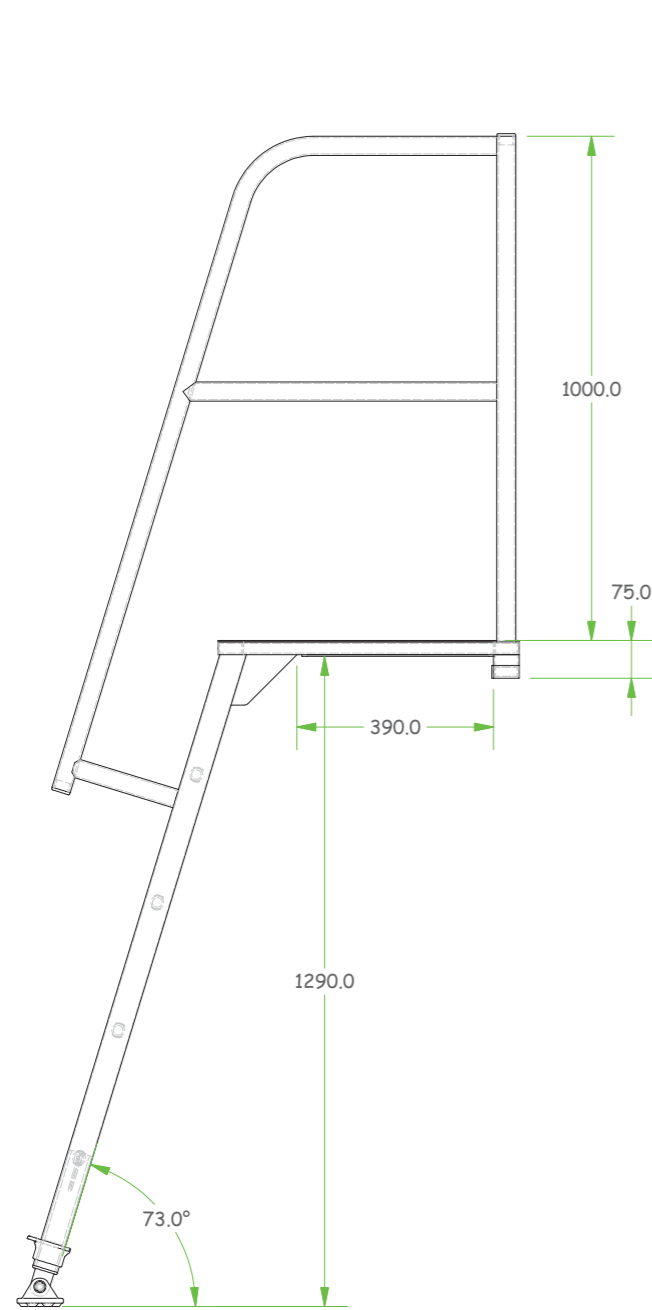

Adjustable legs with upto 100mm of adjustment for levelling

Aluminium Construction

Welded Construction

S.W.L 150KGs



Generic design notes

Platform Design where applicable:

BS1139 Part 3 1994 Specification for prefabricated mobile access and working towers. (Implementation of HD 1004)

BS 5395 Part 3 1985 Stairs Ladders and Walkways.

Platforms Materials where Applicable.

BS 755 Aluminium and aluminium alloys Extruded tube, box section, bars channels & angles. Grade 6082-T6

BS 1490 1970 Specification for aluminium and aluminium alloy ingots and castings for general engineering purposes (Gr-LM6M or LM25FT)

BS EN 485 Aluminium and aluminium alloys Sheet, strips and plate (Gr.5754 for 5 bar tread plate)

Aluminium TIG welding filler material EN ISO 18273 AL 4043a (ASi5) BS:2901 4043a (NG21)

Phenolic Buffalo Board
Surface coating 220gm/m²
SFS 2415/type BS 6566 Part 8
Fire resistance class FMVSS 302
ISO 3795 method BS476 part 7:1987

Polyurethane tyred swivel castors conforming to BS1139 Part 3 1994 HD1004:1992

Steel sections

Flats, Square, Rounds & Angles
BS EN 10056-2:1993
BS EN 10025-2:2004-S275JR

Universal beams, Columns & Channels
BS EN 10034:1993
BS EN 10025-2:2004-S275JR

Fibreglass grating has been tested in accordance with BS 476: Part 7 and met the performance requirements of Class 1

GRP Pultrusion tubing to BS EN 13706

Araldite2000 plus adhesive

GRP Fitting Nylon-6,6 (PA66)
Semicrystalline polyamide nylon

Safe Working Load (Distributed)
275Kgs Per Platform

Total Scaffold Load NOT TO EXCEED
720Kgs

