

Specifications

MODELS GRC™ -12

MEASUREMENTS	Metric	US
Working height*	5.66 m	18 ft
Platform height	3.66 m	12 ft
A B Platform dimensions (length x width)		
Ext Platform dimensions - retracted	99 x 75 cm	39 x 29.5 in
Ext Platform dimensions - extended	1.40 m x 75 cm	55 x 29.5 in
C Height - stowed	1.70 m	67 in
D Length - stowed	1.37 m	5 ft 7.5 in
E Width	80 cm	2 ft 7.5 in
F Ground clearance - centre	6 cm	2.5 in

PRODUCTIVITY

Lift capacity	227 kg	500 lbs
Lift capacity - extension deck	113 kg	250 lbs
Drive speed - stowed	4.0 km/h	2.5 mph
Drive speed - raised	0.8 km/h	0.5 mph
Gradeability**	30%	30%
Turning radius - inside	zero	zero
Turning radius - outside	1.35 m	4 ft 5 in
Raise / lower speed	12/16 sec	12/16 sec
Controls	24V DC proportional	
Tyres - solid non-marking	25 x 8 x 20 cm	10 x 3 x 8 in

POWER

Power source	24V (four 6V 225 Ah batteries)	
Hydraulic system capacity	8.33 L	2.2 gal

SOUND & VIBRATION LEVELS

Sound pressure level (ground workstation)	<70 dBA	<70 dBA
Sound pressure level (platform workstation)	<70 dBA	<70 dBA
Vibration	<2.5 m/s ²	<8 ft 2 in/s ²

WEIGHT***

	948 kg	2,090 lbs
--	--------	-----------

STANDARDS COMPLIANCE CE EN280, PB-10-611-03

* The metric equivalent of working height adds 2 m to platform height. U.S. adds 6 ft to platform height.

** Gradeability applies to driving on slopes. See operator's manual for details regarding slope rating.

*** Weight will vary depending on options and/or country standards.

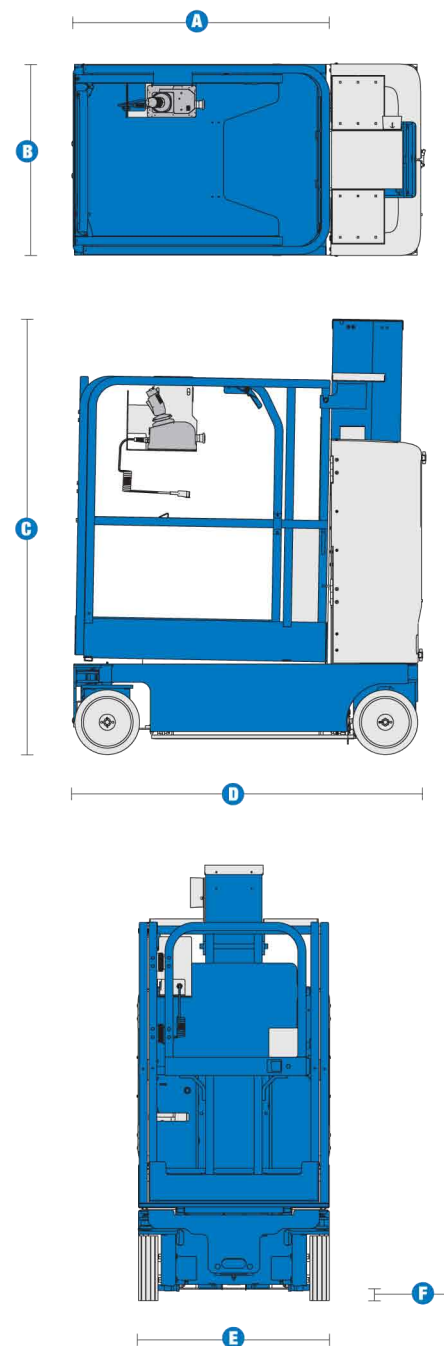

Features

EASILY CONFIGURED TO MEET YOUR NEEDS

PLATFORM

- Steel platform and extension deck with swing gate

POWER

- 24V (four 6V 225 Ah batteries)

TYRE

- Non-marking solid tyres

STANDARD FEATURES

MEASUREMENTS

GRC™-12

- 18 ft (5.66 m) working height
- 12 ft (3.66 m) platform height
- Up to 500 lb (227 kg) lift capacity

PRODUCTIVITY

- Steel platform and extension deck with swing gate
- Auxiliary platform lowering
- Low 39 cm (15.5 in) platform entry height
- Steel tube-in-tube mast system
- Compact base 80 cm x 1.40 m (29.5 x 55 in)
- Ground clearance 6 cm (2.5 in) (stowed)
- Fully proportional lift and drive controls
- Battery charge indicator
- Onboard diagnostic system
- AC power to platform
- Work station trays
- Descent and tilt alarm
- Zero inside turning radius
- Dual wheel brakes
- Hydraulic brake release
- Pothole protection
- Hinged rear ABS covers for easy access to all major electrical and hydraulic components
- Tie down attachment points
- Overhead crane attachment point
- Large forklift pockets access
- Non-marking solid tyres
- Certified load sensor

POWER

- Automatic 25 amp battery charger



OPTIONS & ACCESSORIES

PRODUCTIVITY

- Dual flashing beacons
- Motion alarm
- Fluorescent tube caddy
- Automotive horn

POWER

- Maintenance-free batteries