

Specifications

MODELS	GS™-1532		GS™-1932	
	Metric	US	Metric	US
Working height maximum*	6.6 m	21 ft	7.8 m	25 ft
A Platform height maximum	4.6 m	15 ft	5.8 m	19 ft
B Platform length - outside	1.63 m	5 ft 4 in	1.63 m	5 ft 4 in
extended	2.54 m	8 ft 4 in	2.54 m	8 ft 4 in
Slide-out platform extension deck	91 cm	3 ft	91 cm	3 ft
C Platform width - outside	74 cm	2 ft 5 in	74 cm	2 ft 5 in
Guardrail height:	1.10 m	3 ft 7 in	1.10 m	3 ft 7 in
Toeboard height	15 cm	6 in	15 cm	6 in
D Height - stowed: folding guardrails	2.06 m	6 ft 9 in	2.10 m	6 ft 11 in
rails folded	1.72 m	5 ft 8 in	1.75 m	5 ft 9 in
E Length - stowed	1.83 m	6 ft	1.83 m	6 ft
Length - stowed extended	2.72 m	8 ft 11 in	2.72 m	8 ft 11 in
F Width	81.3 cm	2 ft 8 in	81.3 cm	2 ft 8 in
G Wheelbase	1.32 m	4 ft 4 in	1.32 m	4 ft 4 in
H Ground clearance - centre	6 cm	2.4 in	6 cm	2.4 in
I - with pothole guards deployed	2 cm	0.75 in	2 cm	0.75 in

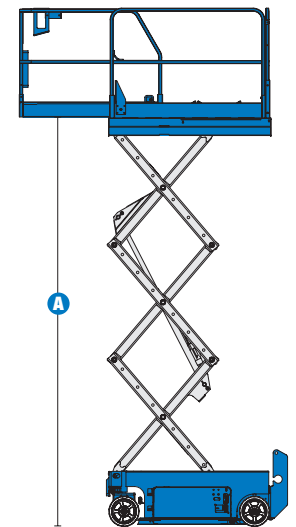
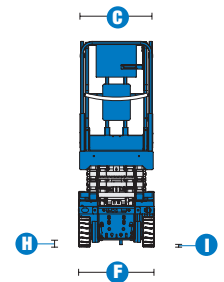
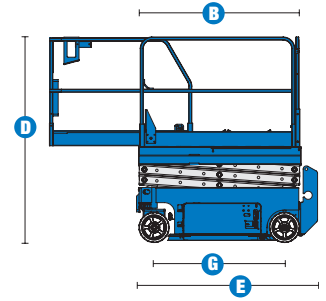

PRODUCTIVITY

Max platform occupancy (indoor/outdoor)	2/1	2/1	2/1	2/1
Lift capacity	272 kg	600 lbs	227 kg	500 lbs
Drive speed - stowed	4.0 km/h	2.5 mph	4.0 km/h	2.5 mph
Drive speed - raised	0.8 km/h	0.5 mph	0.8 km/h	0.5 mph
Gradeability**	30%	30%	25%	25%
Turning radius - inside	zero	zero	zero	zero
Turning radius - outside	1.55 m	5 ft 1 in	1.55 m	5 ft 1 in
Raise / lower speed 16 / 29 sec	16 / 29 sec	16 / 29 sec	16 / 29 sec	16 / 29 sec
Controls	proportional		proportional	
Drive	dual front wheel		dual front wheel	
Multiple disc brakes	dual rear wheel		dual rear wheel	
Tyres - solid non-marking	30 x 11 x 20 cm	12 x 4.5 x 8 in	30 x 11 x 20 cm	12 x 4.5 x 8 in

POWER

Power source	24 V (four 6 V 225 Ah batteries)		24 V (four 6 V 225 Ah batteries)	
Hydraulic system capacity	14.2 L	3.75 gal	14.2 L	3.75 gal

SOUND & VIBRATION LEVELS

Sound pressure level (ground workstation)	<70 dBA	<70 dBA	<70 dBA	<70 dBA
Sound pressure level (platform workstation)	<70 dBA	<70 dBA	<70 dBA	<70 dBA
Vibration	<2.5 m/s ²	<8 ft 2 in/s ²	<2.5 m/s ²	<8 ft 2 in/s ²

WEIGHT***

	1,269 kg	2,797 lbs	1,503 kg	3,313 lbs
--	----------	-----------	----------	-----------

STANDARDS COMPLIANCE

CE EN280, PB-10-611-03

* The metric equivalent of working height adds 2 m to platform height. U.S. adds 6 ft to platform height.
 ** Gradeability applies to driving on slopes, see Operator's Manual for details regarding slope ratings.
 *** Weight will vary depending on options and/or country standards.

Features

STANDARD FEATURES

MEASUREMENTS

GS™-1532

- 6.6 m (21 ft) working height
- Up to 272 kg (600 lb) lift capacity

GS™-1932

- 7.8 m (25 ft) working height
- Up to 227 kg (500 lb) lift capacity

PRODUCTIVITY

- 1.63 m x 74 cm (64 in x 29 in) steel platform
- Folding rails with half-height swing gate
- 91 cm (3 ft) extension deck
- Dual front wheel drive
- Proportional lift and drive
- Universal 20 amp smart charger
- Rear recessed charger receptacle
- 25% to 30% gradeability
- Platform control with battery charge indicator and diagnostic display
- AC power to platform
- Lanyard attachment points
- Manual platform lowering valve
- Emergency stop at both platform and ground controls
- Rear wheel multiple disc brakes
- Front wheel hydraulic dynamic braking
- Manual brake release
- Swing out components trays
- Solid non-marking tyres
- Pothole guards
- Tilt level sensor with audible alarm
- Descent alarm
- Electronic horn
- Hour meter
- Certified load sensor

POWER

- 24 V DC (four 6 V 225 Ah batteries)



OPTIONS & ACCESSORIES

PRODUCTIVITY

- Air line to platform
- Power to platform (plug, socket and ground fault interrupt earth leakage on request)
- Dual flashing beacons
- Motion alarm
- Platform work lights*
- Automotive-style horn
- Biodegradable oil

*Available aftermarket only